



Weyn-Lauwers N.V.

Industriepark-Noord 12
B - 9100 SINT-NIKLAAS

Tel. : 00 32 (0)3 776.34.13
Fax : 00 32 (0)3 778.09.52
weynlauwers@weynlauwers.be
www.weynlauwers.be

**BELLOW GLOBE VALVE
DUCTILE IRON - PN16/25
FIG 473**

DESIGN FEATURES

- ductile iron bellow globe valve dn15 - dn200 PN16/25
- temp : -10°C +350°C
- specifications :
 - not-rising rotating stem and handwheel
 - bolted bonnet and gland packing
 - ! respect the flow ! (indicated by arrow)
 - flanges RF PN25 up to DN50, PN16 over

USE

- common fluids of 2nd group, steam, thermic fluid
- steam max. 10 bar

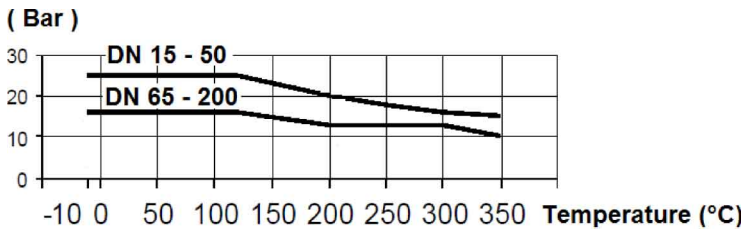

MATERIALS

item	Part name	Material
1	body	ductile iron EN GJS-400-18
2	bonnet	EN GJS-400-18
3	stem	AISI 303 (1.4305)
4	disc	AISI 420 (1.4021)
5	seat	X22 CrNi17 (1.4059)
7	handwheel	EN GJS-400
9	gland	steel EN 10087
10	gasket	graphite
11	packing	graphite
15	screw	steel C35E
16	handwheel nut	steel EN 10087
18	hood	AISI 303 (1.4305)
19	bellow	AISI 316 Ti (1.4571)
20	threaded bushing	steel EN 10087
25	anti turn device	steel EN 10025
	lubricator	brass

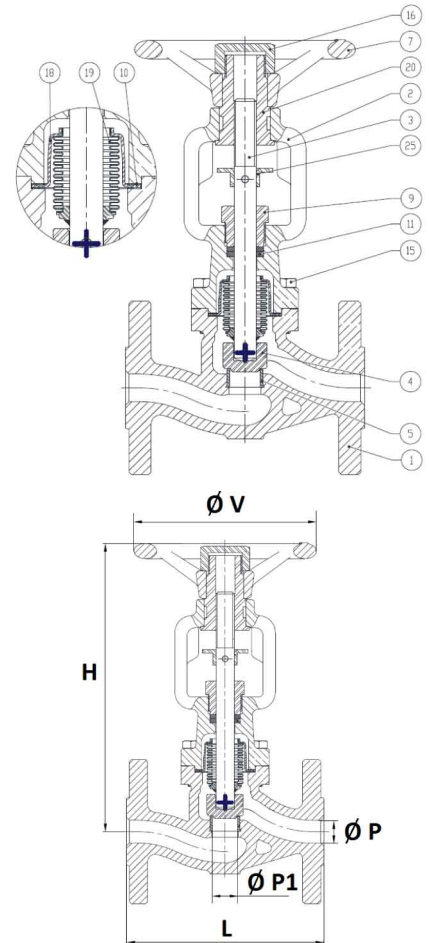

SIZE (in mm)

DN	15	20	25	32	40	50	65	80	100	125	150	200
dia. P	15	20	25	32	40	50	65	80	100	125	150	200
L	130	150	160	180	200	230	290	310	350	400	480	600
dia. P1	16,5	20,5	25,2	30	40,8	50,5	66	81	104,5	126	150,5	205
H	190	195	220	219	256	265	328	341	376	488	531	685
V	120	120	140	140	180	180	200	200	250	275	275	400
kg	3,2	4,4	4,8	6,3	11	13	21,3	26,4	40	53,5	84	157
Kv (m ³ /h)	3,8	7	10	19	35	43	60	110	146	210	300	670
ref.	205965	205966	205967	205968	205969	205970	205971	205972	205973	205974	205975	205976